

## Diameter Ø60mm Shaft Type Absolute Rotary Encoder

### ■ Features

- 12-24VDC power supply of 360-division
- Allows to measure absolute variable angle with BCD code
- Strong against external impact
- Memorizing the absolute position when power is cut off

### ■ Applications

Precision numerical control machine for industrial plant

**⚠ Please read "Caution for your safety" in operation manual before using.**

### ■ Ordering Information

ENP	-	1	-	1	-	1	-	R	-	360	-	P
Series	Output code	Output	Power supply	Revolution direction	Revolution/1 Pulse	Control output						
Diameter Ø60mm shaft type (External shaft diameter: Ø10mm)	1: BCD Code	0: Negative logic 1: Positive logic	0: 5VDC ±5% 1: 12-24VDC ±5%	F: Output value increase at CW direction R: Output value increase at CCW direction	006: 6-division 016:16-division 008: 8-division 024: 24-division 012: 12-division 360: 360-division	P: PNP open collector output N: NPN open collector output						



### ■ Specifications

Item		Diameter Ø60mm shaft type of absolute rotary encoder						
Model	PNP open collector output	ENP-111□-006-P	ENP-111□-008-P	ENP-111□-012-P	ENP-111□-016-P	ENP-111□-024-P	ENP-111□-360-P	
	NPN open collector output	ENP-101□-006-N	ENP-101□-008-N	ENP-101□-012-N	ENP-101□-016-N	ENP-101□-024-N	ENP-101□-360-N	
Resolution*1		6-division	8-division	12-division	16-division	24-division	360-division	
Electrical specification	Output phase	TP (Timing Pulse): 2bit TS (Signal Pulse): 4bit (BCD, EP)	TP (Timing Pulse): 2bit TS (Signal Pulse): 5bit (BCD, EP)	TP (Timing Pulse): 2bit TS (Signal Pulse): 6bit (BCD, EP)	TP (Timing Pulse): 2bit TS (Signal Pulse): 6bit (BCD, EP)	TP (Timing Pulse): 2bit TS (Signal Pulse): 7bit (BCD, EP)	TS (Signal Pulse): 10bit (BCD)	
	Output of phase differences	TP1: 53° ±30' TP2: 15° ±30' P: 60° ±30' TS: 56° ±30'	TP1: 39° ±30' TP2: 15° ±30' P: 45° ±30' TS: 42° ±30'	TP1: 3° ±30' TP2: 15° ±30' P: 30° ±30' TS: 26° ±30'	TP1: 2° ±30' TP2: 11.25° ±30' P: 22.5° ±30' TS: 19.5° ±30'	TP1: 8° ±30' TP2: 3° ±30' P: 15° ±30' TS: 11° ±30'	TS: 1° ±30'	
	Control output	PNP open collector output	Output voltage: Min. (Power supply-1.5V)VDC, Load current: Max. 32mA					
		NPN open collector output	Load current: Max. 32mA, Residual voltage: Max. 1VDC					
	Response time (Rise/Fall)	PNP open collector output	Ton=800ns, Toff=Max. 800ns (Cable length: 1m, I sink=32mA)					
		NPN open collector output	Ton=800ns, Toff=Max. 800ns (Cable length: 1m, I sink=32mA)					
	Max. Response frequency	20kHz						
	Power supply	• 5VDC ±5% (Ripple P-P: Max. 5%) • 12-24VDC ±5% (Ripple P-P: Max. 5%)						
	Current consumption	Max. 100mA (disconnection of the load)						
	Insulation resistance	Min. 100MΩ (at 500VDC megger between all terminals and case)						
Dielectric strength	750VAC 50/60Hz for 1 minute (between all terminals and case)							
Connection	Cable type							
Mechanical specification	Starting torque	Max. 500gf·cm (0.05N·m)						
	Moment of inertia	Max. 300g·cm <sup>2</sup> (3×10 <sup>-6</sup> kg·m <sup>2</sup> )						
	Shaft loading	Radial: 10kgf, Thrust: 2.5kgf						
	Mechanical revolution*2	3,600rpm						
Vibration	1.5mm amplitude at frequency of 10 to 55Hz (for 1 min.) in each X, Y, Z direction for 2 hours							
Shock	Approx. Max. 75G							
Environment	Ambient temperature	-10 to 70°C, storage: -25 to 85°C						
	Ambient humidity	35 to 85%RH, storage: 35 to 90%RH						
Protection structure	IP50 (IEC standard)							
Cable	Ø8mm, 12-wire, Length: 1m, Double shield cable (AWG24, Core diameter: 0.08mm, Number of cores: 40, Insulator diameter: Ø1mm)							
Accessory	Mounting bracket, coupling							
Weight*3	Approx. 478g (approx. 400g)							

\*1: Not indicated resolutions are customizable. \*Environment resistance is rated at no freezing or condensation.

\*2: Make sure that. Max response revolution should be lower than or equal to max. allowable revolution when selecting the resolution.  
 [Max. response revolution (rpm) =  $\frac{\text{Max. response frequency}}{\text{Resolution}} \times 60 \text{ sec}$ ]

\*3: The weight with packaging and the weight in parentheses is only unit weight.

(A)	Photoelectric Sensors
(B)	Fiber Optic Sensors
(C)	Door/Area Sensors
(D)	Proximity Sensors
(E)	Pressure Sensors
(F)	Rotary Encoders
(G)	Connectors/ Sockets
(H)	Temperature Controllers
(I)	SSRs / Power Controllers
(J)	Counters
(K)	Timers
(L)	Panel Meters
(M)	Tacho / Speed / Pulse Meters
(N)	Display Units
(O)	Sensor Controllers
(P)	Switching Mode Power Supplies
(Q)	Stepper Motors & Drivers & Controllers
(R)	Graphic/ Logic Panels
(S)	Field Network Devices
(T)	Software

# ENP Series

## Output Waveform

### • 6-division

Model		ENP-111□-006-P							
Shaft revolution angle (°)		0°	60°	120°	180°	240°	300°	360°	
Output value		6	1	2	3	4	5	6	
Wire color	Wire function								
Black	TP1								
Gray	TP2								
Brown	BCD (2 <sup>0</sup> )								
Red	BCD (2 <sup>1</sup> )								
Orange	BCD (2 <sup>2</sup> )								
White	EP (PARITY)								

※TP1=53°±30', TP2=15°±30' ※P > TS (56°) > TP1 ※P=60°±30'  
 ※Above waveform is based on the positive logic. (The output waveform of negative logic is opposite to above waveform.)

### • 8-division

Model		ENP-111□-008-P									
Shaft revolution angle (°)		0°	45°	90°	135°	180°	225°	270°	315°	360°	
Output value		8	1	2	3	4	5	6	7	8	
Wire color	Wire function										
Black	TP1										
Gray	TP2										
Brown	BCD (2 <sup>0</sup> )										
Red	BCD (2 <sup>1</sup> )										
Orange	BCD (2 <sup>2</sup> )										
Yellow	BCD (2 <sup>3</sup> )										
White	EP (PARITY)										

※TP1=39°±30', TP2=15°±30' ※P > TS (42°) > TP1 ※P=60°±30'  
 ※Above waveform is based on the positive logic. (The output waveform of negative logic is opposite to above waveform.)

### • 12-division

Model		ENP-111□-012-P													
Shaft revolution angle (°)		0°	30°	60°	90°	120°	150°	180°	210°	240°	270°	300°	330°	360°	
Output value		12	1	2	3	4	5	6	7	8	9	10	11	12	
Wire color	Wire function														
Black	TP1														
Gray	TP2														
Brown	BCD (2 <sup>0</sup> )														
Red	BCD (2 <sup>1</sup> )														
Orange	BCD (2 <sup>2</sup> )														
Yellow	BCD (2 <sup>3</sup> )														
Green	BCD (2×10 <sup>0</sup> )														
White	EP (PARITY)														

※TP1=3°±30', TP2=15°±30' ※P > TS (26°) > TP1 ※P=30°±30'  
 ※Above waveform is based on the positive logic. (The output waveform of negative logic is opposite to above waveform.)

# Ø60mm Shaft Absolute Type

## Output Waveform

### • 16-division

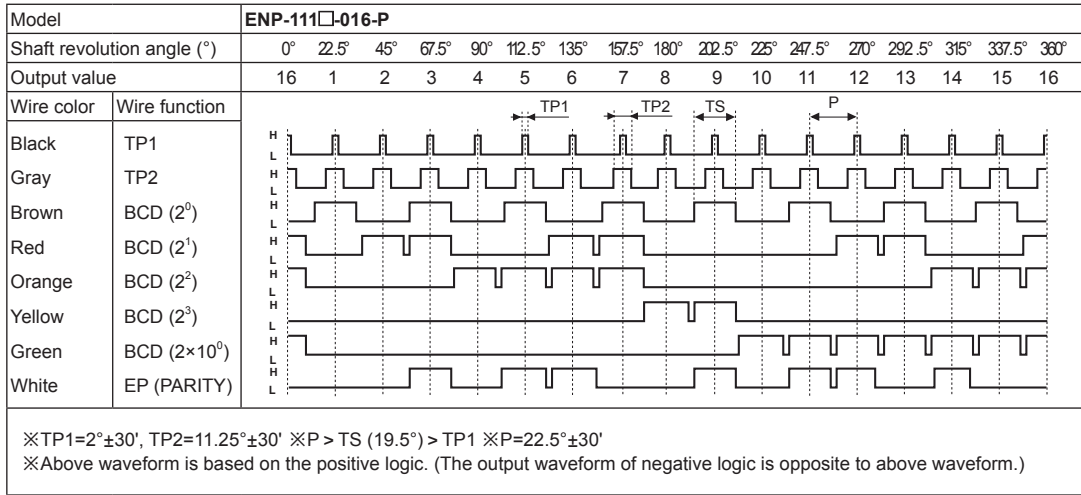

### • 24-division

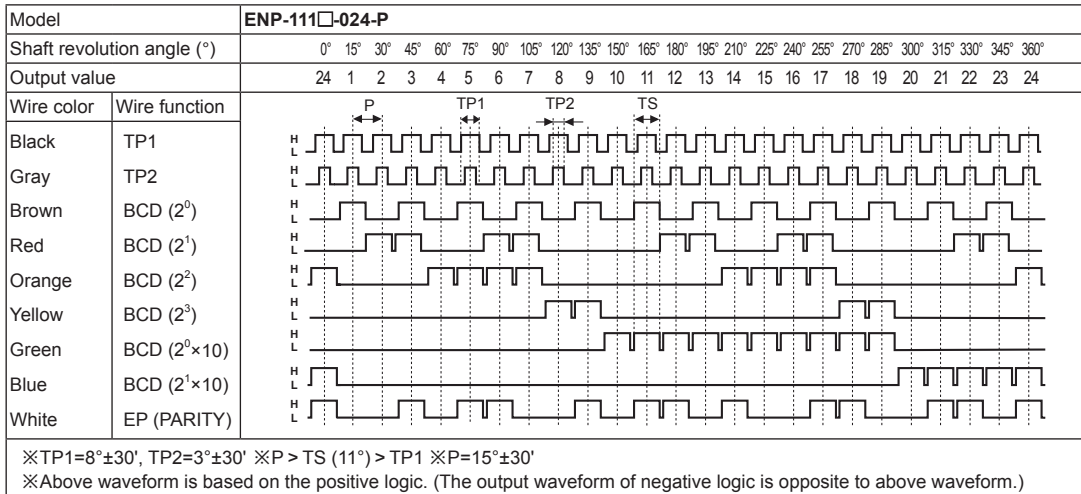

### • 360-division

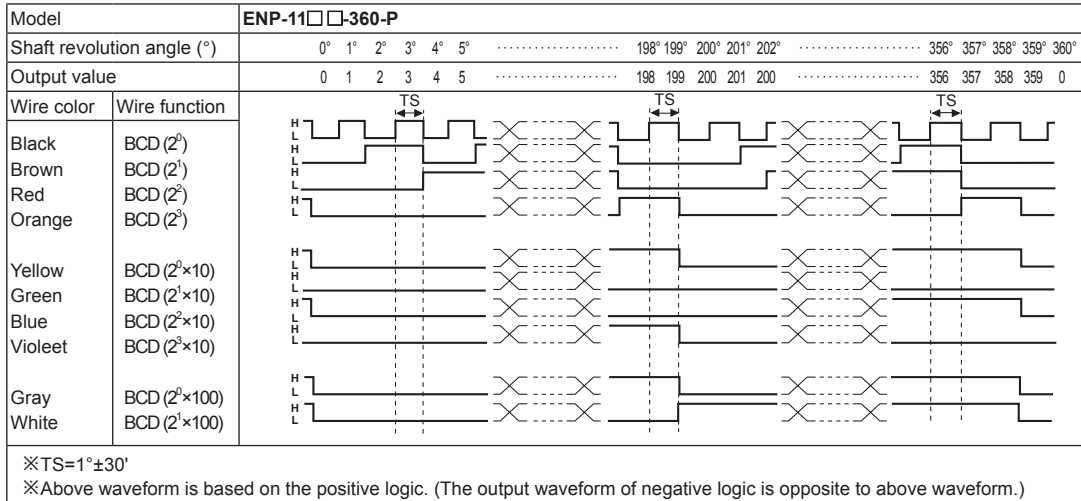

(A) Photoelectric Sensors

(B) Fiber Optic Sensors

(C) Door/Area Sensors

(D) Proximity Sensors

(E) Pressure Sensors

(F) Rotary Encoders

(G) Connectors/ Sockets

(H) Temperature Controllers

(I) SSRs / Power Controllers

(J) Counters

(K) Timers

(L) Panel Meters

(M) Tacho / Speed / Pulse Meters

(N) Display Units

(O) Sensor Controllers

(P) Switching Mode Power Supplies

(Q) Stepper Motors & Drivers & Controllers

(R) Graphic/ Logic Panels

(S) Field Network Devices

(T) Software

# ENP Series

## Control Output Diagram

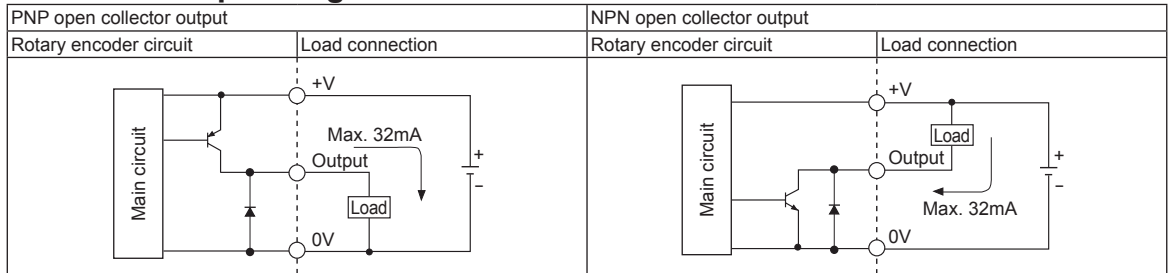

※Output circuit of each output signal is same.

## Connections

Resolution		6-division	8-division	12-division	16-division	24-division	360-division
Wire color	White ※1	+V					
	Black ※1	GND (0V)					
	Shield wire	F.G.					
Output wire	Black	TP1 ※2					2 <sup>0</sup>
	Brown	2 <sup>0</sup>	2 <sup>0</sup>	2 <sup>0</sup>	2 <sup>0</sup>	2 <sup>0</sup>	2 <sup>1</sup>
	Red	2 <sup>1</sup>	2 <sup>1</sup>	2 <sup>1</sup>	2 <sup>1</sup>	2 <sup>1</sup>	2 <sup>2</sup>
	Orange	2 <sup>2</sup>	2 <sup>2</sup>	2 <sup>2</sup>	2 <sup>2</sup>	2 <sup>2</sup>	2 <sup>3</sup>
	Yellow	N·C	2 <sup>3</sup>	2 <sup>3</sup>	2 <sup>3</sup>	2 <sup>3</sup>	2 <sup>0</sup> ×10
	Green	N·C	N·C	2 <sup>0</sup> ×10	2 <sup>0</sup> ×10	2 <sup>0</sup> ×10	2 <sup>1</sup> ×10
	Blue	N·C	N·C	N·C	N·C	2 <sup>1</sup> ×10	2 <sup>2</sup> ×10
	Purple	N·C					2 <sup>3</sup> ×10
	Gray	TP2 ※2					2 <sup>0</sup> ×100
	White	EP (PARITY) ※3					2 <sup>1</sup> ×100
	Shield wire	F.G.					

※1: Insulator external diameter is  $\varnothing 1.5\text{mm}$ .

※2: TP1/TP2: Because low resolution model has long output signal period, this signal for enable is easy to determine signal recognition point about output.

※3: EP: Parity signal. It outputs odd parity.

※Unused wire must be insulated.

※Encoder case and shield wire must be grounded.

※N·C: Not connected.

※Output cable must not be short-circuited, because Driver IC is used in output circuit.

## Dimensions

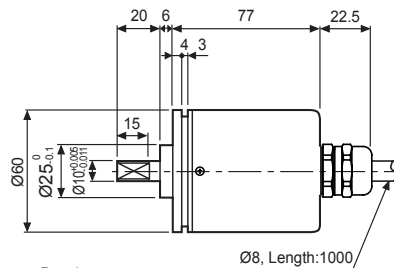
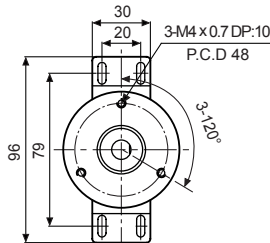

### Bracket

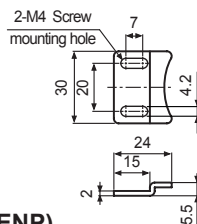

### Coupling (ENP)

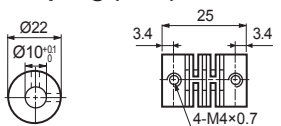

• Parallel misalignment: Max. 0.25mm

• Angular misalignment: Max. 5°

• End-play: Max. 0.5mm

※For parallel misalignment, angular misalignment, end-play terms, refer to page F-71.

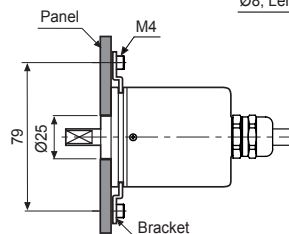

※When mounting the coupling to encoder shaft, if there is big eccentricity or declination between rotating encoder shaft and mate shaft, it may shorten life cycle of the encoder or the coupling.

※Do not load overweight on the shaft.